

A NEW DSC FOR HIGH HEATING AND COOLING RATES MEASUREMENTS

KEN-ICHI HIRANO<sup>1</sup>, TAMIO OHSHIMA<sup>1</sup>, HIROSHI OKAMOTO<sup>2</sup>, RYOZO KATO<sup>2</sup>  
AND AKIKAZU MAESONO<sup>2</sup>

<sup>1</sup> Department of Materials Science, Faculty of Engineering,  
Tohoku University, Sendai 980, Japan

<sup>2</sup> ULVAC SINKU-RIKO CO., LTD., 300 Hakusancho, Midori-ku, Yokohama  
226, Japan

ABSTRACT

A new differential scanning calorimeter (DSC) for high and adjustable heating and cooling rates (up to 200 K/min) and a wide temperature range of measurement (230 - 1050 K) has been developed. Performance and applicability of the new DSC apparatus were examined for precipitation reactions in aluminum alloys. This apparatus, developed mainly for the study of metals and alloys, will also be useful for the study of other materials.

INTRODUCTION

Recent demands for the thermal analyses in the course of rapid heating or cooling materials are increasing owing to the increasing interest in metastable materials. For instance, in case of studying thermal stability and interrelation between metastable phases formed in a precipitation process in alloys, thermal analyses during heating at conventional heating rates, up to several 10 K/min, are not sufficient to distinguish the reaction peaks due to formation or resolution of various metastable phases by the differences in their kinetic properties. By measurements at higher heating rates and also at some combined modes of higher heating and cooling rates, new information on phase transformation processes or metastable states in materials can be furnished. The present work has been carried out to develop a new DSC for high heating and cooling rates measurements.

## INSTRUMENTATION

The requirements of the new DSC were as follows:

1. Realization of high heating and cooling rates:  
up to 200 K/min.
2. Wide temperature range of measurement:  
room temp. to 1300 K.
3. Feasible sensitivity: higher than 50  $\mu$ W.

In order to realize these requirements, it was considered to be most reasonable to adopt the power-compensation type DSC.

Fig.1 shows the structures of the detecting unit and the specimen holder of the apparatus. In order to attain a high cooling rate, the two specimen holders are separately installed in small rooms in an aluminum block which can be cooled by either water or liquid nitrogen. As shown in Fig.1-b) and c), one of the main innovations on the heating system is the use of a compact and sensitive heater-temperature sensor for a specimen-holder. The apparatus has only one pair of heaters, one in the sample holder and the other in the reference holder. The heater is constructed by putting a platinum resistance temperature sensor in a small and thin ( 6 x 10 x 1 mm ) alumina body. The heater thus can sense its own average temperature and at the same time can heat its holder according to a programmed heating condition, and also can compensate the temperature difference between the sample and the reference holder,  $\Delta T_{S-R}$ . In order to increase sensitivity for detecting the temperature difference,  $\Delta T_{S-R}$ , a fine Pt-13%Rh/Pt thermocouple of  $\phi 0.1$  mm is inserted slightly under the center of the upper surface of each holder.

Fig.2 shows the block diagram of the apparatus. To eliminate the temperature difference,  $\Delta T_{S-R}$ , the compensation power,  $dQ/dt$ , is supplemented to the heating power and is also transferred to data processing unit as the DSC output.

To reduce the temperature gap between the surface of the holder and the specimen in each specimen holder, and to improve adjustability of the heat balance between the reference holder and the sample holder during heating and cooling, a heat flow shielder was set up just above each specimen as shown in Fig.1-b).

In this way, the goals aimed at and described above, could almost be attained.

a) Detecting unit

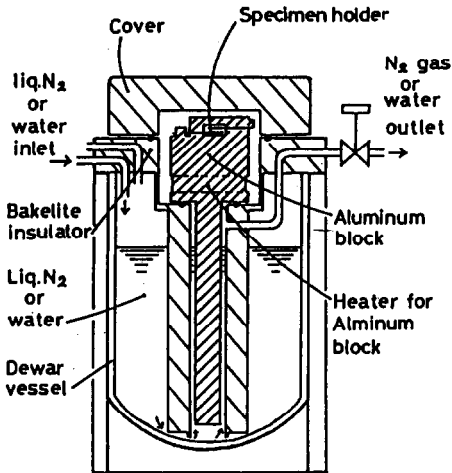

b) Specimen holder

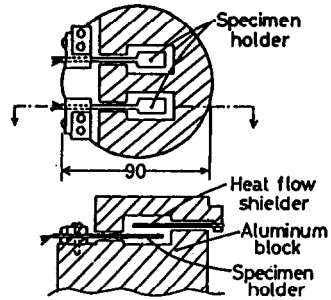

c) Specimen holder (enlarged)

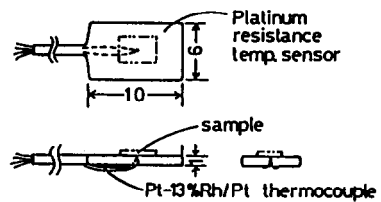

Fig.1 Structure of the detecting unit in the new DSC apparatus.

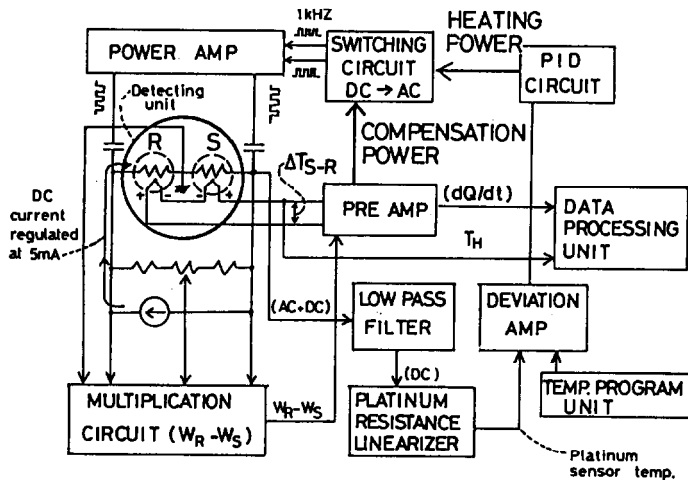

Fig.2 Block diagram of the new DSC for high heating and cooling rates measurement. R: Reference holder, S: Sample holder.

## RESULTS AND DISCUSSIONS

### i) Temperature correction

Since the sample temperature is measured by the thermocouple

set up at the center of the sample holder, the temperature gap ( $\Delta T_H = T_H - T_S$ , see Fig.3-a) between the sample,  $T_S$ , and the thermocouple in the sample holder,  $T_H$ , must be checked for temperature correction. Further, in the case when the temperature is controlled by a rather complicated combination of heating and cooling modes, shift of the temperature of sample holder thermocouple from the platinum resistance heater-sensor ( $\Delta T_R = T_R - T_H$ , (see Fig.3-a)), must be checked to decide the holder temperature.

The temperature gap,  $\Delta T_H$ , was examined with a specimen of pure nickel (ca. 2.5 x 3.5 x 0.3 mm) and a fine  $\phi 25 \mu\text{m}$  C-A thermocouple (as shown in Fig.3-b). The dependence of  $\Delta T_H$  on the sample holder temperature,  $T_H$ , is almost independent of the change in heating or cooling rate in the range of heating rate between -150 and 150 K/min.

The heating and cooling rate dependence of the temperature shift,  $\Delta T_R$ , was also examined (as shown in Fig.3-c). It was confirmed that  $\Delta T_R$  depended on  $T_H$  linearly at various heating and cooling rates in the temperature range between 300 and 1050 K.

Based on these results, the data processing to deduce  $T_S$  from  $T_H$  and also to calculate the upper and lower limits of the controlling temperature were carried out.

#### ii) Measurement of melting points of pure Sn

To check the temperature correction, the melting point of pure Sn was measured at various heating rates. A small piece of pure Sn of 2mg was melted on a piece of aluminum (2 x 3 mm) of 15  $\mu\text{m}$  thickness set up on the sample holder. As shown in Fig.4, for the heating rate up to 200 K/min, the accuracy of the measured melting points,  $T_m$ , of Sn is within 1 K. The corresponding temperatures of the platinum resistance heater-sensor,  $T_R$ , and the holder thermocouple,  $T_H$ , are also shown in Fig.4, where  $T_R$  shows a tendency of the heater-sensor's overheating above the sample temperature as the heating rate increases.

#### iii) Study on precipitation processes in Al-alloy

Al-Zn-Mg-Cu alloy is known as one of the age-hardenable high strength aluminum alloys. Its properties are related to the finely dispersed precipitates of various kinds of the metastable phases. DSC measurement is useful to study the precipitation processes in alloys and many works have been carried out. One of the problems in the previous DSC studies on the precipitation process in alloys was the determination of the baseline for the DSC curves

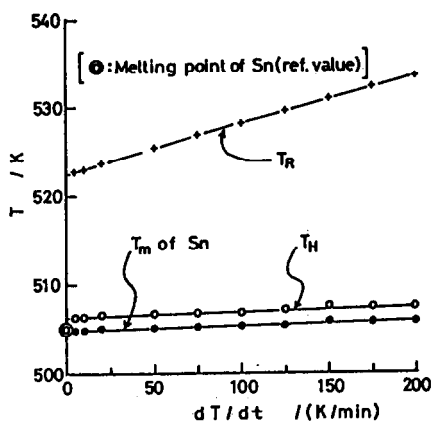
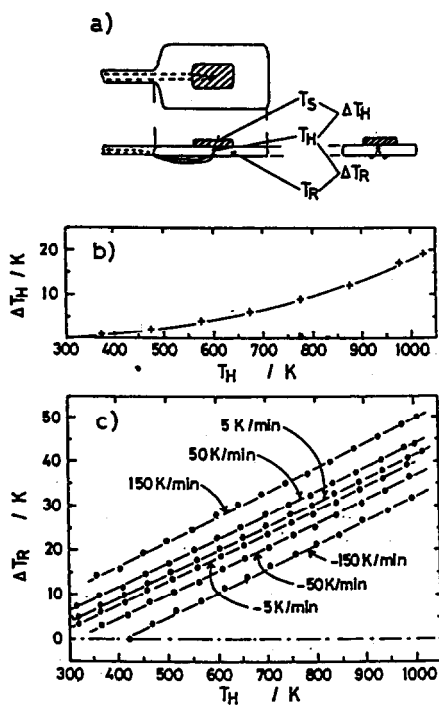

Fig.4 Dependence of the melting point,  $T_m$ , of Sn measured by the new DSC on heating rates.

Fig.3 Results on temperature correction. a) Definition of  $\Delta T_H$  and  $\Delta T_R$ , b) Dependence of  $\Delta T_H$  on the sample holder temperature,  $T_H$ , and c) Dependence of  $\Delta T_R$  on  $T_H$  for each heating rate.

with the appearance of multiple exo- and endothermic peaks in order to discriminate these peaks experimentally. We applied repeated DSC measurements interrupted by rapid cooling as a method to determine the baseline. Fig.5 shows an example of such measurements. Al-2.6mol%Zn-2.9mol%Mg-1.0mol%Cu alloy was solution heat treated (kept at 753 K(480°C) for 20 min and quenched into water), then the 1st heating DSC measurement was carried out to 473 K(200°C) at 50 K/min and the sample was cooled to room temperature at 150 K/min. Then, the 2nd run was done to a little higher temperature than in the 1st run. The measurement and cooling were repeated to make 5 runs. By using these DSC curves, it was possible to fix the most feasible base line as shown in Fig.5. In this way, it was found that peaks, P and Q, in the 1st heating measurement are due to rather big exothermic reactions and that there exists one endothermic peak, R, and two exothermic peaks, S and U, in the 2nd curve. In the 3rd and 4th heating runs, only one endothermic reaction, V, appears in the higher and broad temperature range. When the sample was heated up to 773 K(500°C), a big

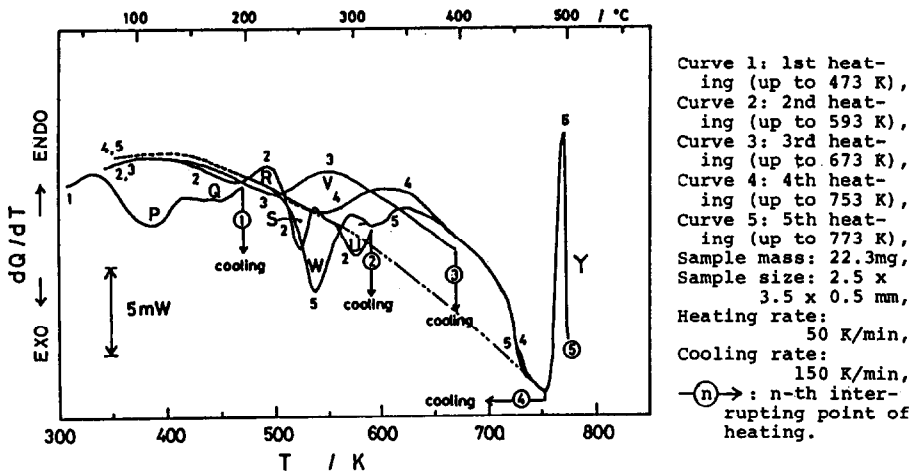

Fig.5 Repeated DSC measurement of Al-2.6mol%Zn-2.9mol%Mg-1.0mol%Cu alloys, interrupted by rapid cooling.

exothermic peak, W and a sharp endothermic peak, Y, appear around 540 K and 773 K (500°C), respectively. The observed peaks could be attributed to the following reactions:

- Exothermic Peak P: Formation of G.P.B. zones,
- Peak Q: Formation of another kind of G.P. zones,
- Peak S: Precipitation of metastable  $\eta'$  phase,
- Peak U: Precipitation of  $\eta$  phase,

Endothermic Peak V: Dissolution of  $\eta'$  and  $\eta$  phases.

It is well known that G.P.B. zones, G.P. zones and  $\eta'$  phase are important in strengthening this alloy, thus examination of the conditions for formation and their stability is important.

The new apparatus can also be used to determine the activation energy of each reaction peak by kinetic analyses of the dependence of the peak temperature on the heating rate.

## CONCLUSION

A new DSC for high heating and cooling rates (up to 200 K/min) and a wide temperature range of measurement (230 - 1050 K) has been developed and applied successfully to the study on phase transformation in an aluminum alloy. Used for a conventional DSC measurement, this apparatus also permits us to make quick thermal analyses one after another.